

## VERY LOW VOLTAGE 4 Megabit (256K x 16) UV EPROM and OTP EPROM

### DATA BRIEFING

- VERY LOW VOLTAGE READ OPERATION:  
2.7V to 5.5V
- FAST ACCESS TIME: 150ns
- LOW POWER "CMOS" CONSUMPTION:
  - Active Current 15mA
  - Standby Current 20 $\mu$ A
- PROGRAMMING VOLTAGE: 12.75V
- PROGRAMMING TIMES of AROUND 24sec.  
(PRESTO II ALGORITHM)
- M27W402 is PROGRAMMABLE as  
M27C4002 with IDENTICAL SIGNATURE

### DESCRIPTION

The M27W402 is a low voltage, low power 4 Megabit UV erasable and electrically programmable EPROM, ideally suited for handheld and portable microprocessor systems requiring large programs. It is organized as 262,144 by 16 bits.

The M27W402 operates in the read mode with a supply voltage as low as 2.7V. The decrease in operating power allows either a reduction of the size of the battery or an increase in the time between battery recharges.

The M27W402 can also be operated as a standard 4 Megabit EPROM (similar to M27C4002) with a 5V power supply.

### Signal Names

|                 |                |
|-----------------|----------------|
| A0 - A17        | Address Inputs |
| Q0 - Q15        | Data Outputs   |
| $\bar{E}$       | Chip Enable    |
| $\bar{G}$       | Output Enable  |
| V <sub>PP</sub> | Program Supply |
| V <sub>CC</sub> | Supply Voltage |
| V <sub>SS</sub> | Ground         |

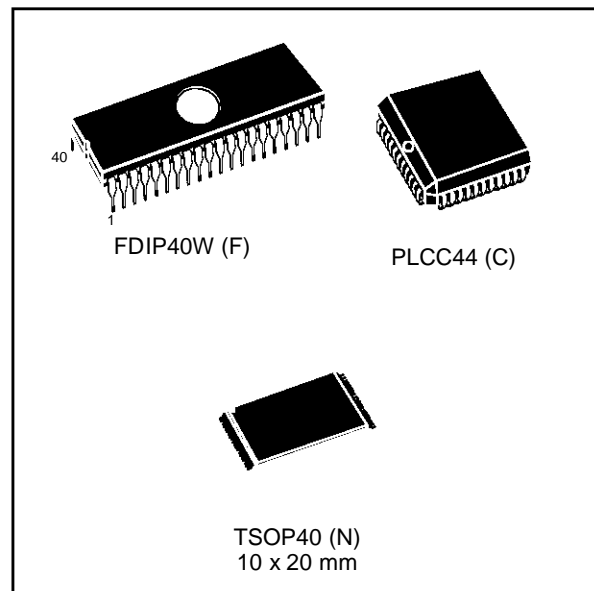

### Logic Diagram

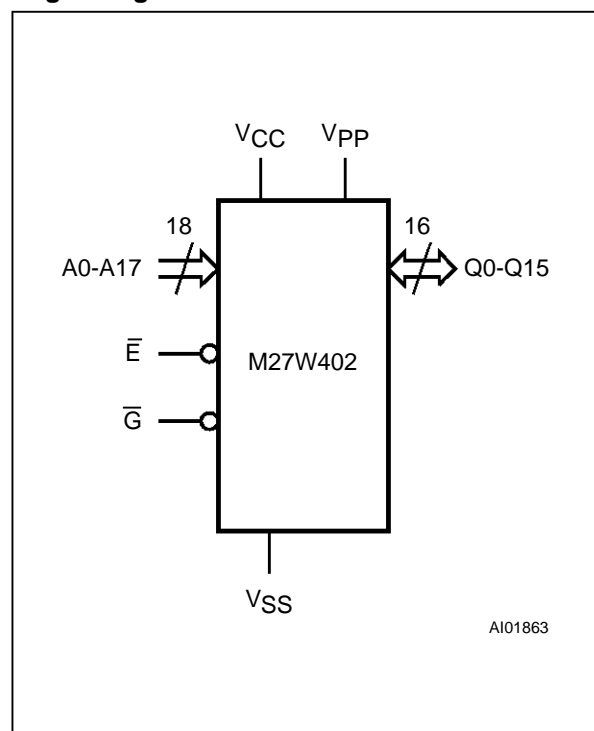

# M27W402

## DIP Pin Connections

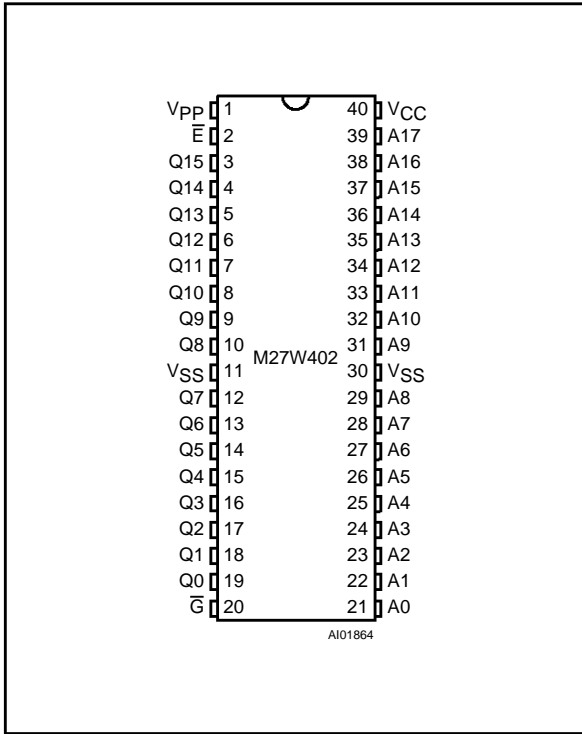

## LCC Pin Connections

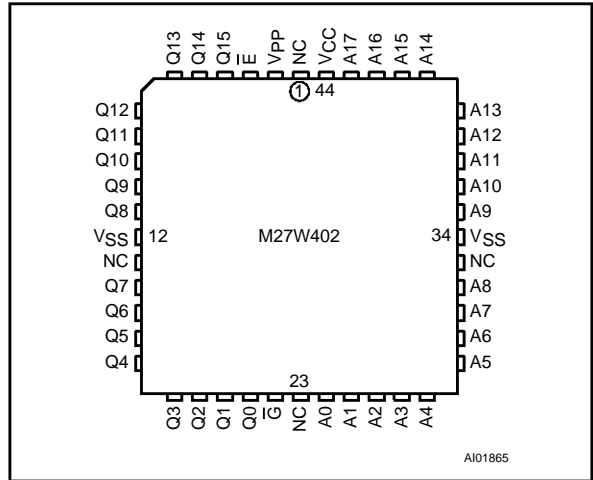

## Ordering Information Scheme

For a list of available options refer to the current Memory Shortform catalogue.

For further information on any aspect of this device, please contact the SGS-THOMSON Sales Office nearest to you.

Example: M27W402 -150 K 4 TR

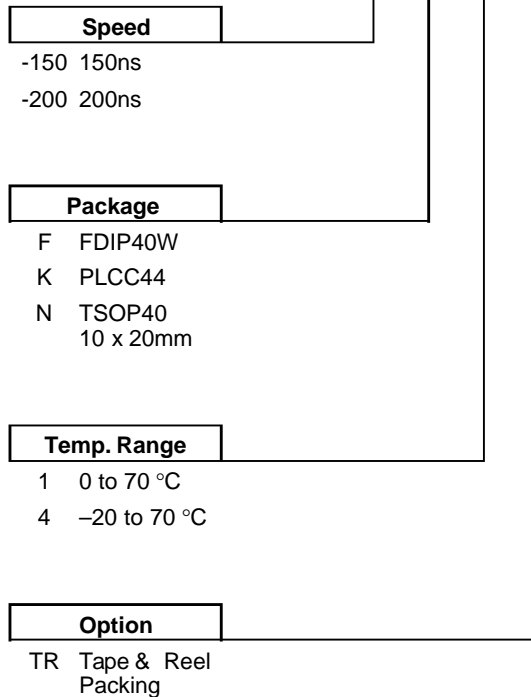

## TSOP Pin Connections

